

MANUAL POLLY MERCHANDISING ELEMENTS

Modular frame

Modular shelf clamp

Polly Brand items

Modular extension

**Modular stepped shelf exten-
der (optional)**



for more information visit www.howtopolly.com



Modular frame



the box contains:

vertical frame parts

1 plastic bag with:

- 1 spanner key 13 mm
- 2 bolts and nuts M8

2 pre assembled side supports with clamps ^{A)}

horizontal frame parts

2 corner elements Ø 16 mm

1 tube 550 x Ø19 mm ^{B)}

3 tubes 850 x Ø 19 mm ^{C)}

1 tube 800 x Ø 16 mm ^{D)}

- A)** pre assembled side support cover heights between 1450-2250 mm.
- B)** the horizontal tube of 550 mm covers width between 740-1000 mm.
- C)** the tubes of 850 mm are used at height between 1000-1550 mm.
the horizontal tube of 850 mm covers width between 1000-1400 mm.
- D)** the Ø16mm connector tube of 800 mm covers width up to 2100 mm.
an extension set is available to cover wider presentations.

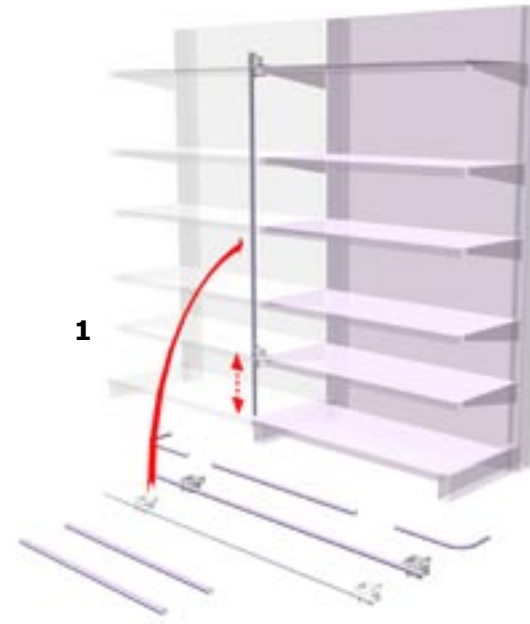

1

mount the pre-assembled side support

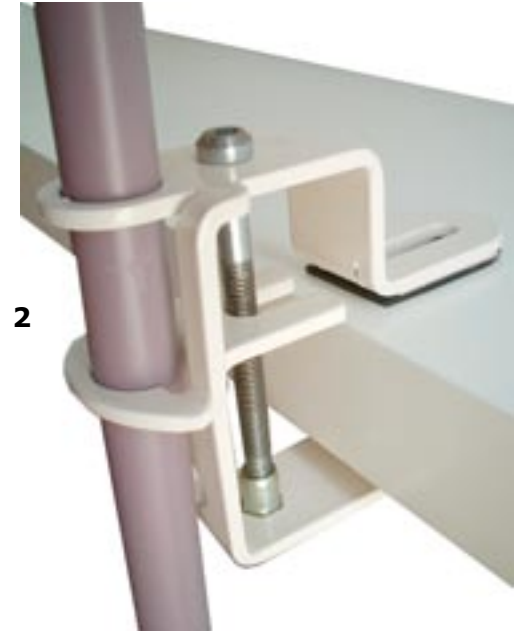

2

place clamps like this

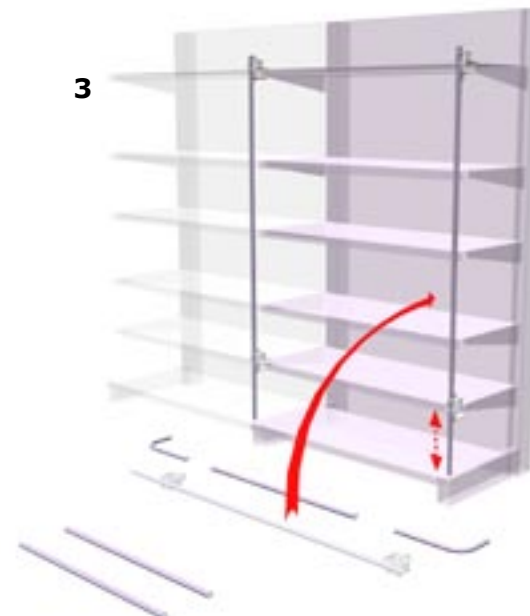

3

mount the 2th pre assembled side support
and adjust to height

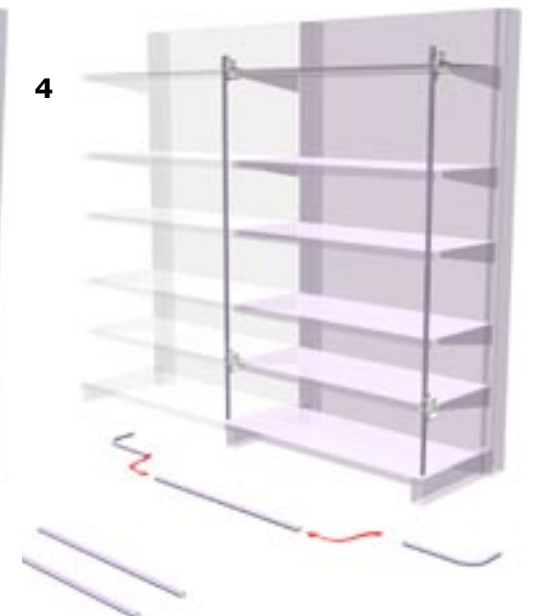

4

assemble the top part

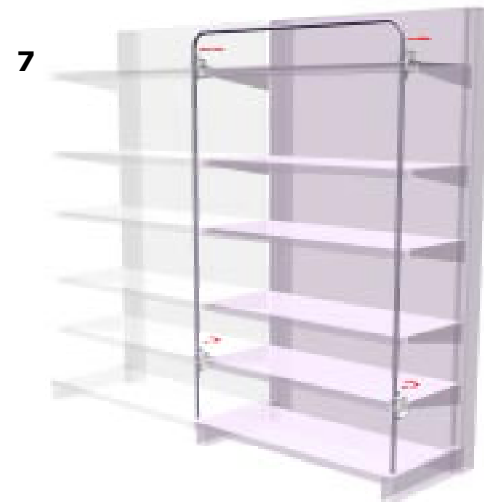
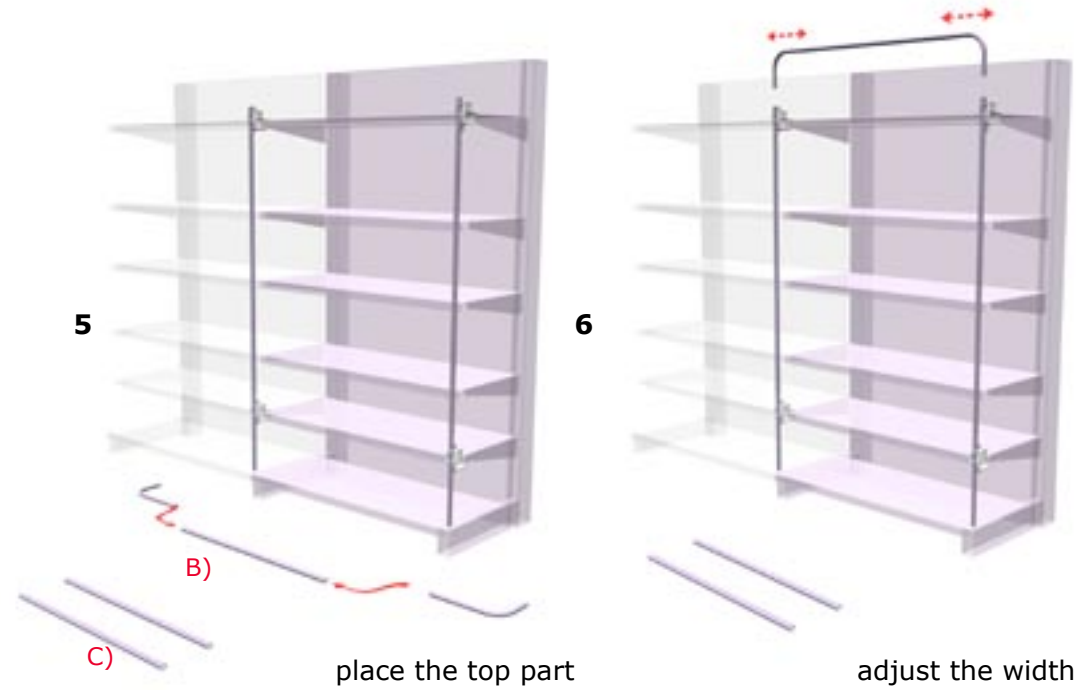

horizontal frame parts

2 corner elements

- 1 tube 550 mm Ø 19 mm** ^{B)}
- 1 tube 850 mm Ø 19 mm** ^{C)}
- 1 tube 800 mm Ø 16 mm** ^{D)}

^{B)} the horizontal tube of 550 mm covers width between 740-1000 mm.
^{C)} the horizontal tube of 850 mm covers width between 1000-1400 mm.
^{D)} the Ø16mm connector tube of 800 mm covers width up to 2100 mm.
 an extension set is available to cover wider presentations

the frame is now ready to
mount the brand items

more details on modular
clamp on next page

tighten the clamps

Modular shelf clamp

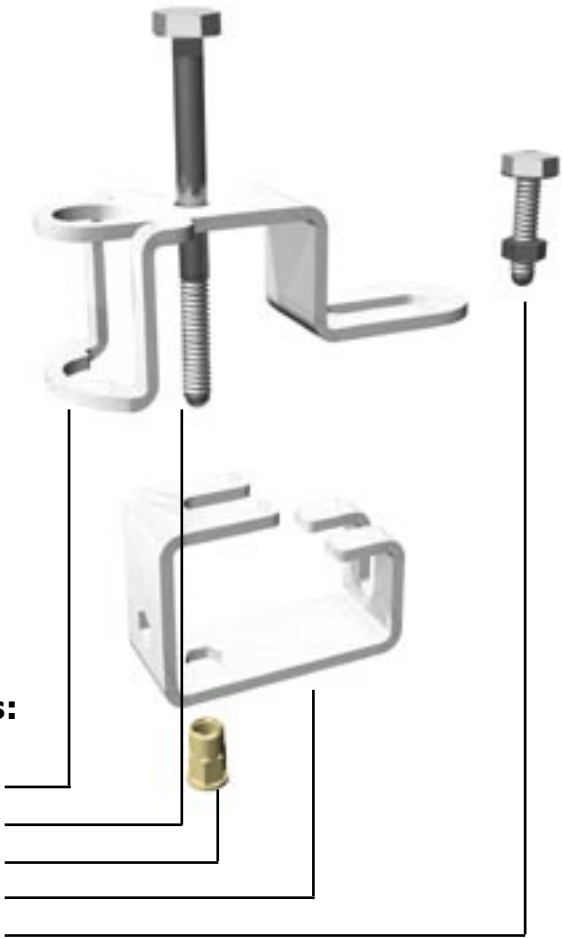

the clamp in parts:

- shelf part
- main bolt
- insert nut
- sliding part ¹⁾
- wire shelf bolt ²⁾

¹⁾ the sliding part can be used in two positions to avoid obstructions
²⁾ this additional bolt+nut can be used only on wire shelves

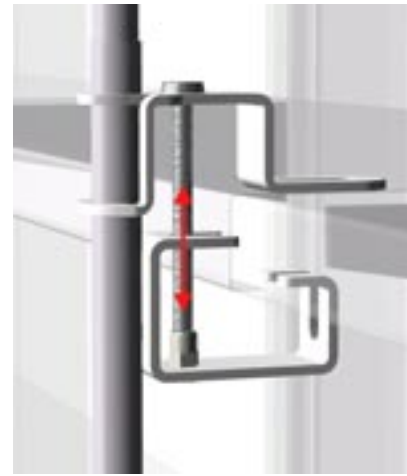

sliding part in general position
will suit standard shelves

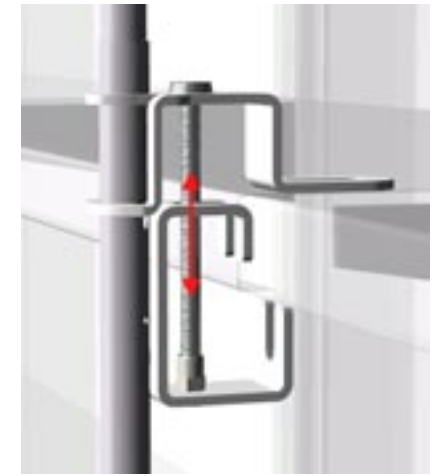

sliding part vertical
used with limited back space

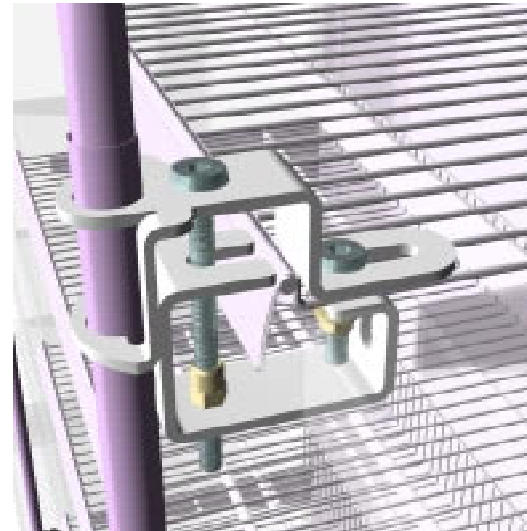

typical wire shelf situation
note the additional bolt on shelf



shelf clamp mounted with
Polly brand flowers

Polly Brand items

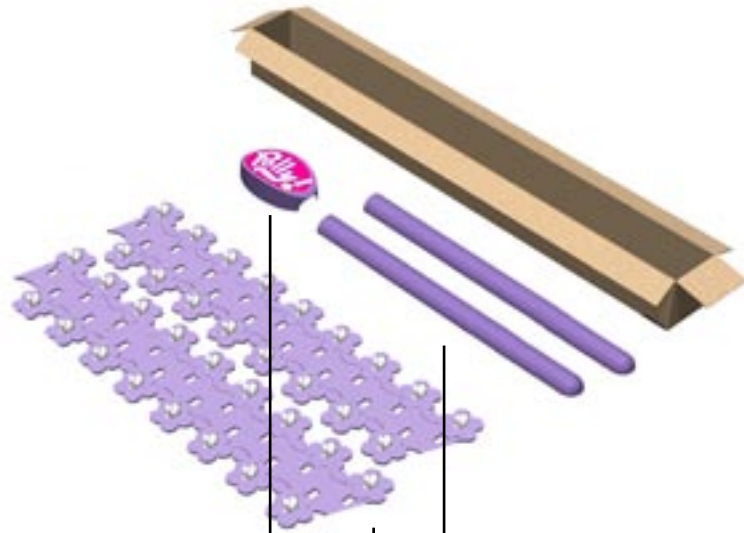

the box contains:

1 Polly horizontal header logo

2 Polly vertical brand strips ^{A)}

2 Polly horizontal header bars ^{B)}

1) the flower strips can be cut to size with scissors.

2) Polly header bars can be cut to appropriate size with scissors.

Important:

an extension set is available to cover wider presentations and contains additional header elements

1

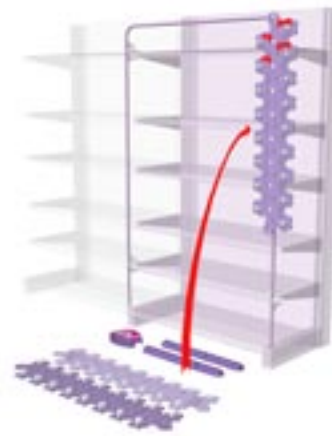

start from the top

2



fold the flowers towards you

3



click the clips on the tube

4



backside close-up

Polly Brand items



typical Polly Pocket Brand presentation

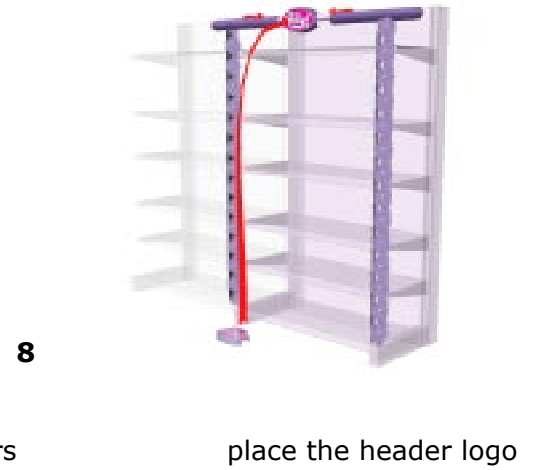
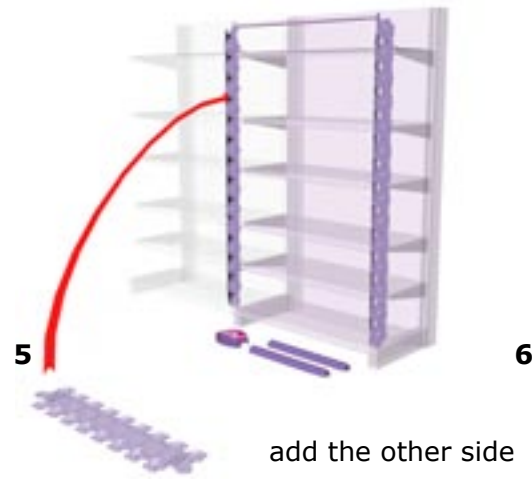

Modular frame extension

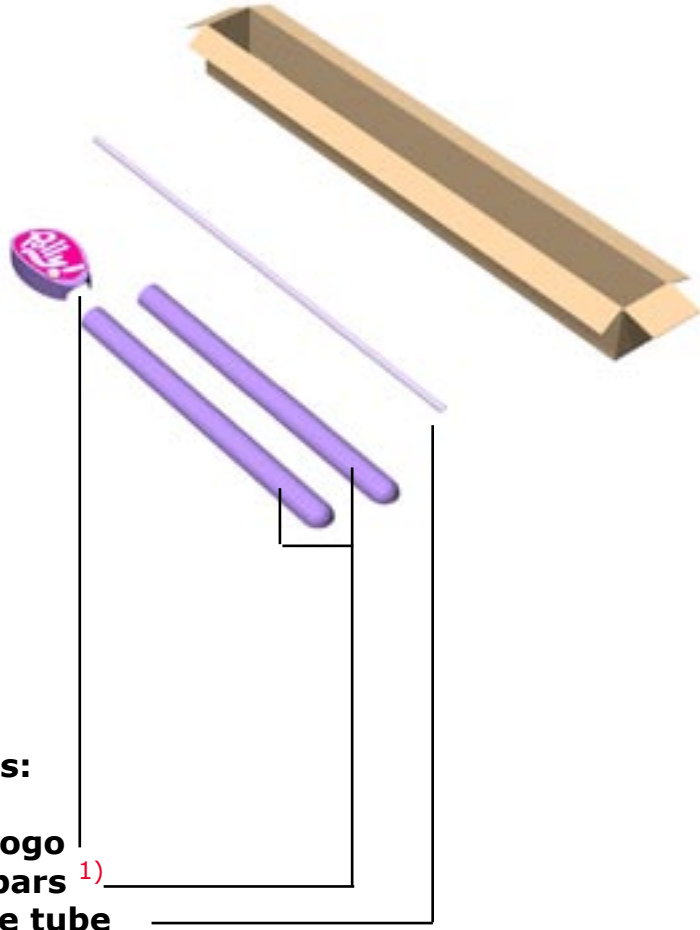

the box contains:

- 1 polly header logo
- 2 polly header bars 1)
- 1 extension core tube

1) Polly header bars can be cut to appropriate size with normal scissors.

one extension set covers shelf space up to 2-3 shelf meters.
its aim is to add branding to the presentation.

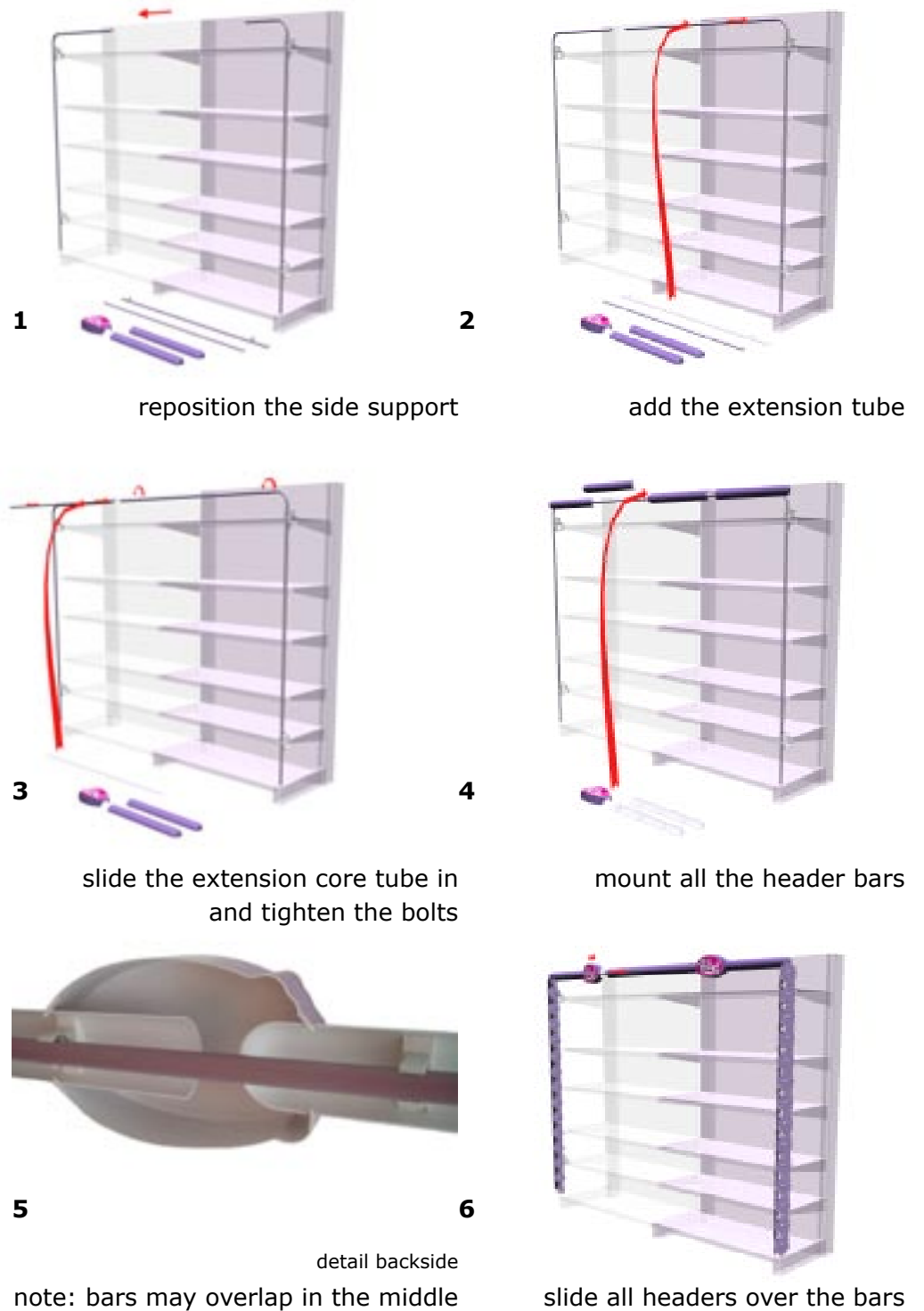

1

reposition the side support

2

add the extension tube

3

slide the extension core tube in
and tighten the bolts

4

mount all the header bars

5

detail backside

note: bars may overlap in the middle

6

slide all headers over the bars

Modular stepped shelf extension

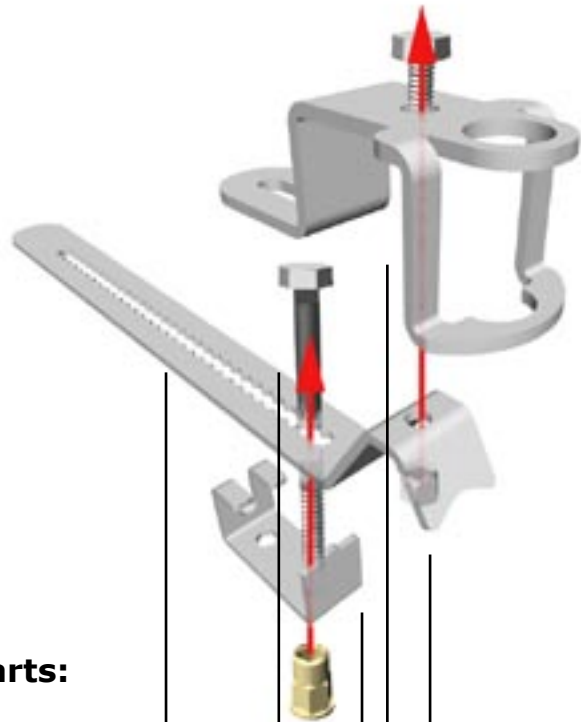

extension parts:

extender part

medium bolt

rivet nut

sliding part ¹⁾

shelf clamp part

short bolt & nut ²⁾

1) the sliding part can be used in two positions to avoid obstructions

2) this additional bolt+nut is normally used on wire shelves



the stepped shelf extender is used when shelves have different depth



the extension is first mounted to the clamp position the extender on the designated shelf lock the extender with a short bolt to the sliding part