

MANUAL Little People MERCHANDISING ELEMENTS



Modular frame

Modular shelf clamp

Little People Brand items

**Modular stepped shelf extender
(optional)**



for more information visit www.howtomattel.com



Modular frame (part of brand presentation)

the box contains:

2 tubes 850 mm^{A)}

1 plastic bag with:

- 1 allen key 6 mm
- 4 bolts and nuts M8
- 1 spare tube clip

2 stepped shelf extensions (optional)

2 pre assembled side supports with clamps^{B)}

2 corner elements

1 tube 850 mm^{C)}

1 tube 550 mm^{D)}

- ^{A)} the tubes of 850 mm are used at height between 1000-1550 mm.
 - ^{B)} pre assembled side support cover heights between 1450-2250 mm.
 - ^{C)} the horizontal tube of 850 mm covers width between 1000-1400 mm.
 - ^{D)} the horizontal tube of 550 mm covers width between 740-1000 mm.
- an extension set is available to cover wider presentations

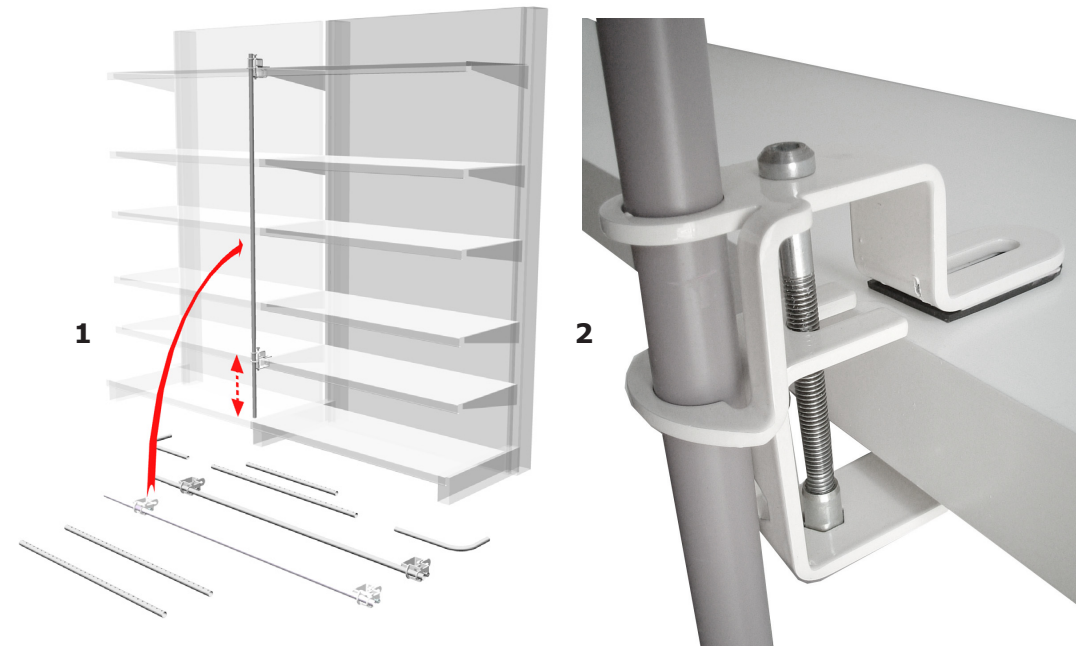

1 mount the pre-assembled side support

2 place clamps like this

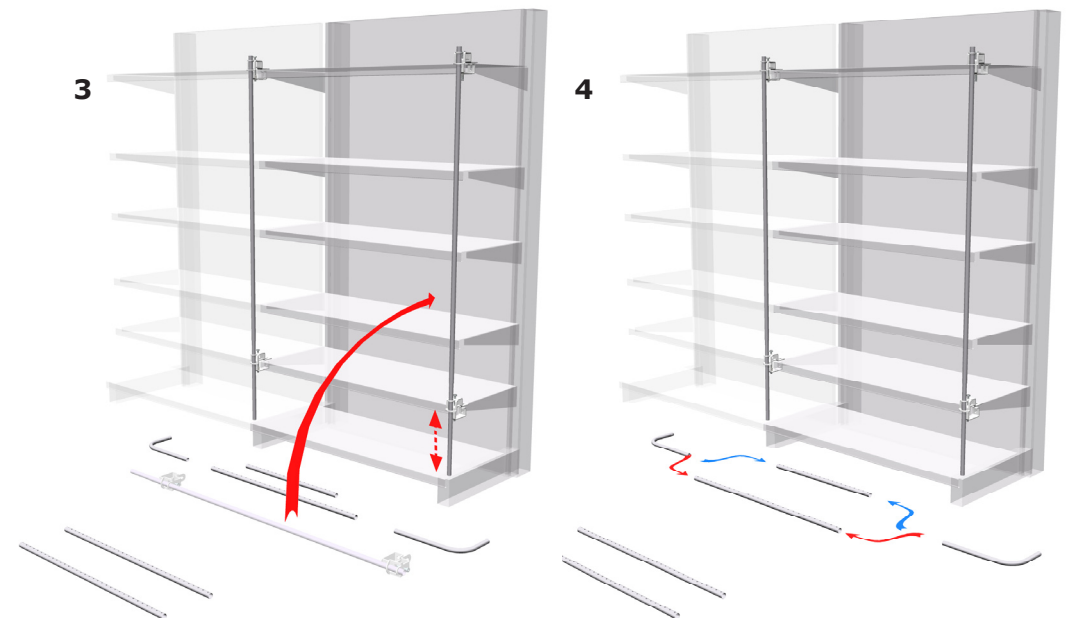

3 mount the 2nd pre assembled side support and adjust to height

4 assemble the top part

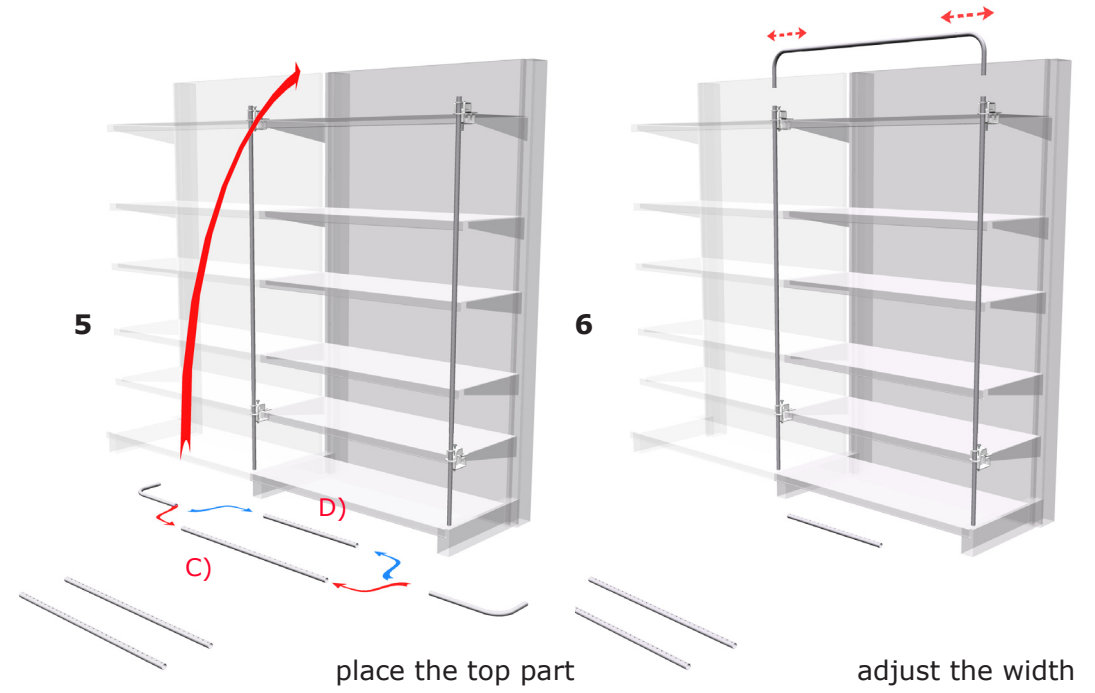

the frame is now ready to
mount the brand items

more details on stepped
shelving on page 4

more details on modular
clamp on next page

Modular shelf clamp

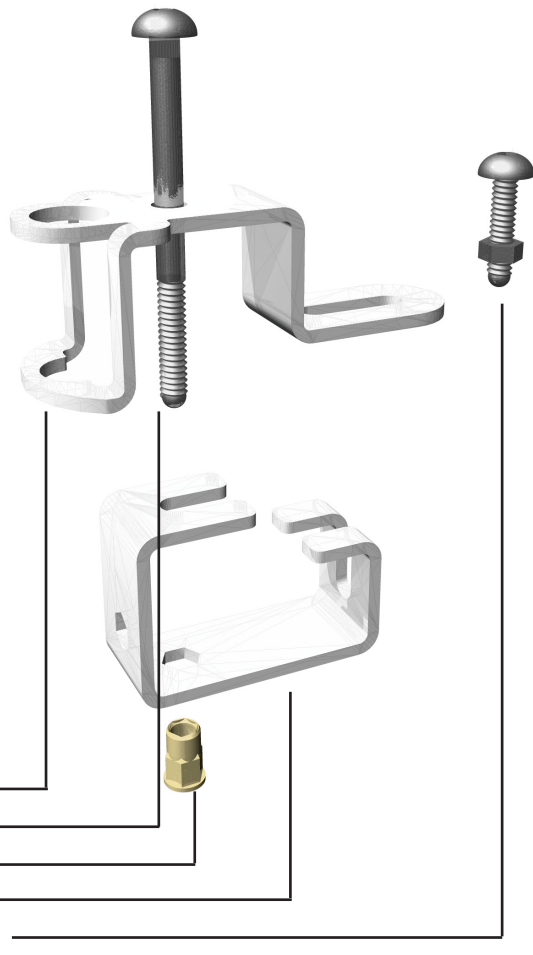

- 1) the sliding part can be used in two positions to avoid obstructions
- 2) this additional bolt+nut can be used only on wire shelves

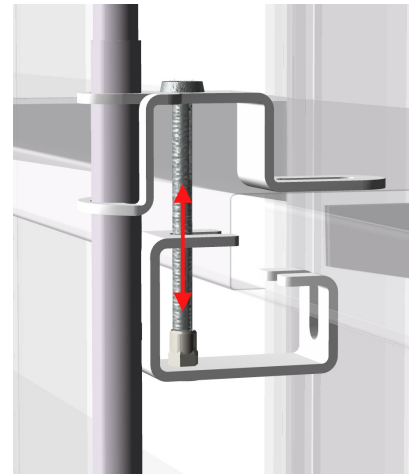

sliding part in general position
will suit standard shelves

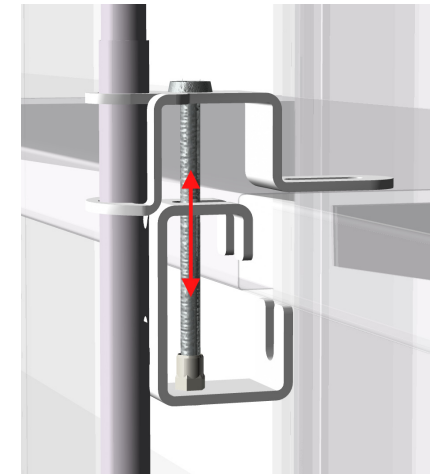

sliding part vertical
used with limited back space

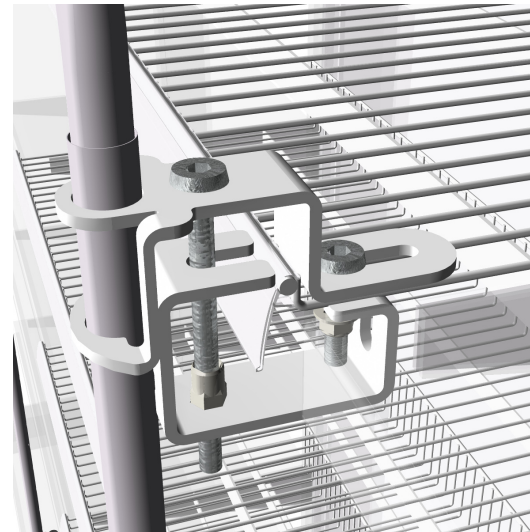

typical wire shelf situation
note the additional bolt on shelf



shelf clamp mounted with
Hot Wheels brand strips

Little People Brand items



the box contains:

- 1 L. P. header logo
- 2 L.P. horizontal covers ^{A)}
- 2 L.P. vertical brand covers top ^{A)}
- 2 L.P. vertical brand covers bottom ^{A)}

^{A)} all brandstrips and covers can be cut to size with scissors.

Important:
an extension set is available to cover wider presentations and contains additional header elements

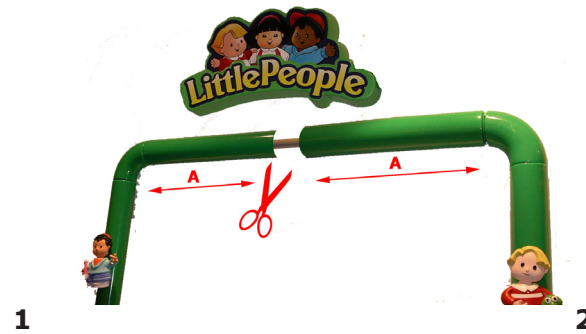

1 cut horizontal covers at equal length the header will conceal the small gap

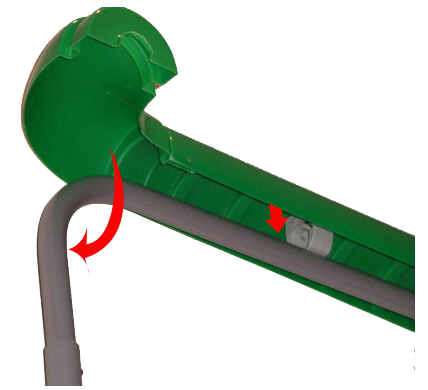

2 click hor. covers to the frame



3 firmly tighten the clips

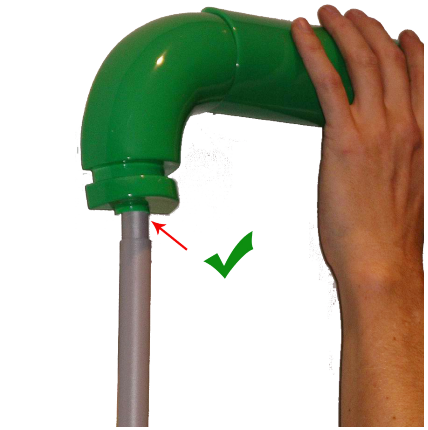

4 corner piece in right position



5 place vertical brand strips

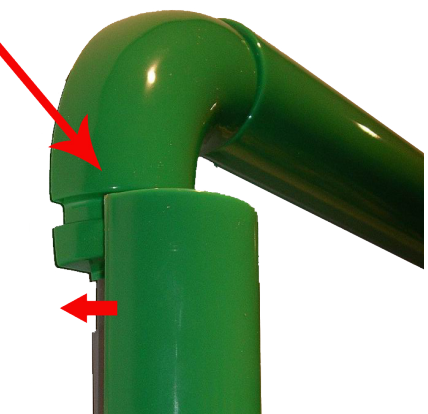

6 note connection of strips

Little People Brand items

7

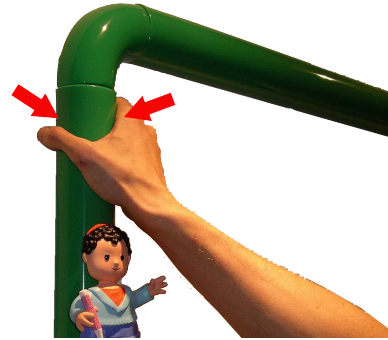

press firmly to lock clips

8



clips should not interfere with clamps

9

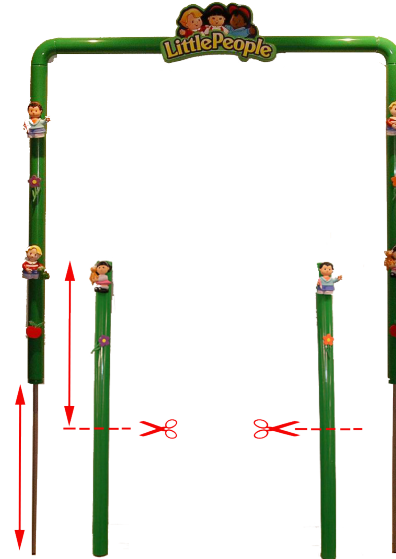

cut the lower parts to fit
keep the brand frame 10 cm from
the floor

10



tilt the header in position

11

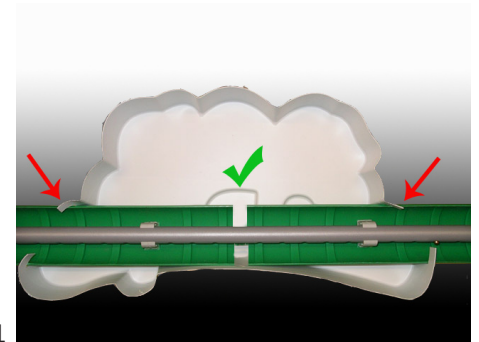

press the edges down
note the gap in the middle

Modular stepped shelf extension

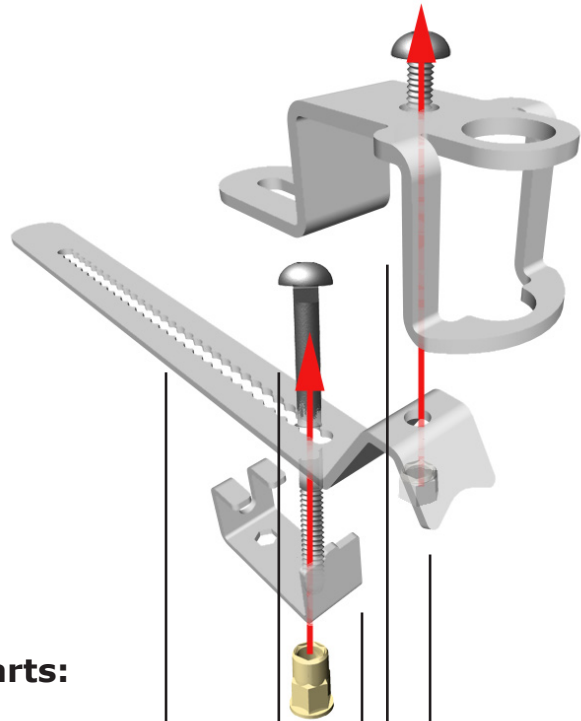

extension parts:

extender part

medium bolt

rivkle nut

sliding part ¹⁾

shelf clamp part

short bolt & nut ²⁾

1) the sliding part can be used in two positions to avoid obstructions

2) this additional bolt+nut is normally used on wire shelves



the stepped shelf extender is used when shelves have different depth



the extension is first mounted to the clamp position the extender on the designated shelf lock the extender with a short bolt to the sliding part